

CR-5P Seismic, Earthquake and Structural Monitoring System

Features

- ❑ Multichannel modular central seismic / earthquake / structural monitoring and recording system
- ❑ Accessible from anywhere around the world through Internet
- ❑ Cable saving via distributed data acquisition nodes
- ❑ 3, 6 or 9 Channel Modules, 19" rack mountable and expandable to several hundred channels
- ❑ 18 or 24 Bit resolution
- ❑ Sampling rates 100 and 200 SPS, Optionally 10, 20, 50, 250 SPS
- ❑ External 12 VDC Power Supply
- ❑ Rugged industrial portable or fixed housing
- ❑ Galvanic isolation and over voltage protection
- ❑ GPS synchronised recording available
- ❑ Real-time display of dynamic channels
- ❑ Large capacity data storage options
- ❑ On-line surveillance, diagnostics, self checking and reporting system
- ❑ Alarm Relays, SMS / Email messenger



Outline

The CR-5P was developed out of years of experience in seismic instrumentation as well as structural monitoring of civil engineered structures such as dams, nuclear power plants, pipelines, tunnels, bridges, tall buildings and unique structures all over the world. CR-5P provides scientists with a state of the art high dynamic seismic recorder and engineers with a valuable tool to fully understand and analyse the dynamics of structures in the operating environment. With CR-5P the seismic activity at a region or the dynamics affecting a structure including but not limited to acceleration, velocity, displacement, temperature, current, wind speed, wind direction, stress and pressure may be monitored and recorded.

Dynamic channel sample rates of 100 and 200 SPS, optionally 10, 20, 50, 250 SPS can be provided. The system bases on synchronised multi-channel A/D converters. After hardware anti-aliasing filtering the signals are digitised using the over-sampling and decimation technique resulting in superior data quality.

The heart of the CR-5P software is GeoDAS, a proven data logger and data analysis package developed by GeoSIG Ltd. GeoDAS is frequently used in large seismic networks. GeoDAS integrated into the CR-5P central recording monitoring system provides a richly configured set of user-friendly capabilities, displays and analytical tools running under Windows XP operating system.

In addition to the near real-time display of the dynamic channels the system provides static data like mean, max, min, and peak values. The CR-5P monitors the real-time data generated by each of the sensors attached to the system and compares the measured data to five fully independent alarm trigger criteria. The ring buffer size, the post event time, trigger thresholds and relay alarm on/off times may be selected by the customer.

A comprehensive surveillance, diagnostics reporting system through alarm relays, SMS and E-mail can be optionally provided.

Specifications CR-5P Seismic, Earthquake and Structural Monitoring System

Set-up and Configuration

All the necessary parameter and configuration settings are selectable using the CR-5P software interface. The configuration of the CR-5P stored in non volatile system memory to allow automatic restart in case of a system failure or manual hard reset.

Data Analysis

The GeoDAS program provides comprehensive time history data evaluation. Once a data file has been opened the analysis menu is available for functions like FFT, response and terzband spectras, etc. for determination of mode and natural frequencies of structures.

Sensor

The CR-5P offers the most flexible adaptation of sensors to meet the needs of structural measuring. Numerous channels may be configured. The sensors which can be used but not limited to are:

GeoSIG AC-xx accelerometer:

| | |
|-------|--|
| AC-2x | 0.1 to 100 Hz, ± 2 to ± 0.1 g |
| AC-4x | DC to 100 Hz, ± 4 to ± 0.625 g |
| AC-6x | DC to 100 Hz, ± 3.5 to ± 0.5 g |

GeoSIG VE-xx seismometers / velocity sensors:

| | |
|-------|--|
| VE-1x | 1 to 100 Hz, ± 100 to ± 1 mm/s |
| VE-2x | 4.5 to 100 Hz, ± 100 to ± 1 mm/s |
| VE-3x | 4.5 to 315 Hz, 27.3 Vs/m |
| VE-5x | 1 to 315 Hz, 100 to 1'000 Vs/m |

Other sensors can be Strain Gage, Weather Station, Wind direction & speed, humidity, air pressure, temperature, etc.

Digitizer

| | |
|-----------------------------|---|
| Type | CR-5PADxx (xx: 18 or 24) 9 channel modules 3 x Triaxial connectors or 9 x Uni-axial connectors |
| A/D Converter | 24 Bit (synchronised) per dynamic channel |
| A/D Sampling rate | 250 kSPS / 9 channels (over sampling) |
| Dynamic Range | CR-5PAD18 > 110 dB _{rms} CR-5PAD24 > 130 dB _{rms} |
| Resolution | CR-5PAD18 > 120 dB _{rms} CR-5PAD24 > 140 dB _{rms} |
| Sampling Rate (per 3 chn) | 100, 200 SPS Optionally 10, 20, 50, 250 SPS |
| Configurable input Voltages | differential $\pm 1, 5, 10, 20$ V single ended $\pm 1, 5, 10$ V single ended 2.5 V ± 2.5 V current loop: 0 ... 20 mA |

Recording Options

| | |
|-----------------------------|--|
| Internal Computer | CR-5PRHDx (x: 40 to 160 GByte) Embedded board with storage on Hard Disk: 40 – 160 GByte or Compatible In-Rack Laptop |
| External or Remote Computer | Minimum performance: Pentium IV 1.7 GHz 1 GByte RAM, 80 GByte HDD Mouse*, Keyboard* VGA display* *not required for normal operation |
| Communication | via CR-5PCOM or CR-5PRHDx Ethernet TCP/IP (see Figure 3) |

Data Recording

| | |
|-----------------|-------------------------------|
| Type | Continuous and/or Event Based |
| Pre-event-Time | 1 to 100 seconds |
| Post-event-Time | 1 to 100 seconds |

Triggering

| | |
|--------------------|--|
| Level Triggering | |
| Lower band limit | 0.1 Hz (40 dB/decade) |
| Upper band limit | 100 Hz @ 200 SPS (40 dB/decade) |
| Range | 0.003 to 100 % of full scale |
| STA/LTA Triggering | |
| STA-Base | 0.1 to 100 seconds |
| LTA-Base | 5 to 100 seconds |
| STA/LTA-Ratio | 1 to 60 dB |
| Power Supply | 12 VDC distributed within modules, see Figure 2. External power adapter / charger CR-5PPWR for 230 VAC / 50 Hz or 115 VAC / 60 Hz |
| Battery | Optional Rechargeable External, 12 VDC, 70 to 240 Ah Lead battery |
| Autonomy | Depends on the system and sensor configuration |
| Power consumption | Depends on the system and sensor configuration |

Time Base

| | |
|--------------------------|---|
| External Code Compatible | NMEA |
| Standard clock accuracy | 10 – 20 ppm (5-10 min/year) |
| External time interfaces | GPS System < $\pm 1/2$ sample Synch Cable < $\pm 1/2$ sample Ethernet (NTP) < ± 10 ms |
| Power for GPS receiver | 12 VDC (power cycled every 15 min) Surge Protected |

Environment / Housing

| | |
|-------------------------|--|
| Operational temperature | - 20 °C to + 60 °C |
| Storage temperature | - 40 °C to + 90 °C |
| Humidity | 0 % to 100 % RH (non condensing) |
| Type | Polyethylene/Aluminium CR-5PHx (x: 2, 3, 4 or 6) stacking portable case, vibration protection optionally available |
| Painted Steel | Fixed wall mount cabinet |
| Size | Dimensions vary due to the size/protection |
| Width | 530 – 550 mm Polyethylene/Aluminium 600 mm Painted Steel |
| Depth | 330 – 350 mm Polyethylene/Aluminium add 150 mm on depth for connectors 580 mm Painted Steel |
| Height | 160 – 340 mm Polyethylene/Aluminium add height of multiple cases 370 mm Painted Steel |
| Weight | Local PE connection recommended 20 kg typical for 9 channel recording unit |
| Protection | IP65, EMI & Earthquake resistant Should be protected from direct environmental effects (sunlight, rain, etc). |

Self Test

| | |
|-------------------|--|
| Sensor test | Square pulse |
| GPS | Signal lock |
| Visual Indicators | LED Indicators - for the channel network activity - on each channel connector - on each 9 channel module |
| System Status | Checked on the continuous basis through the data interrogation (AC power, Battery Voltage, Time Sync Source) |

Alarm Option

| | |
|--------------|--|
| Alarm levels | 0.003 to 100 % of full scale (User programmable per axis) |
| Method | SMS (GSM Short Message Service) or e-mail |

Specifications CR-5P Seismic, Earthquake and Structural Monitoring System

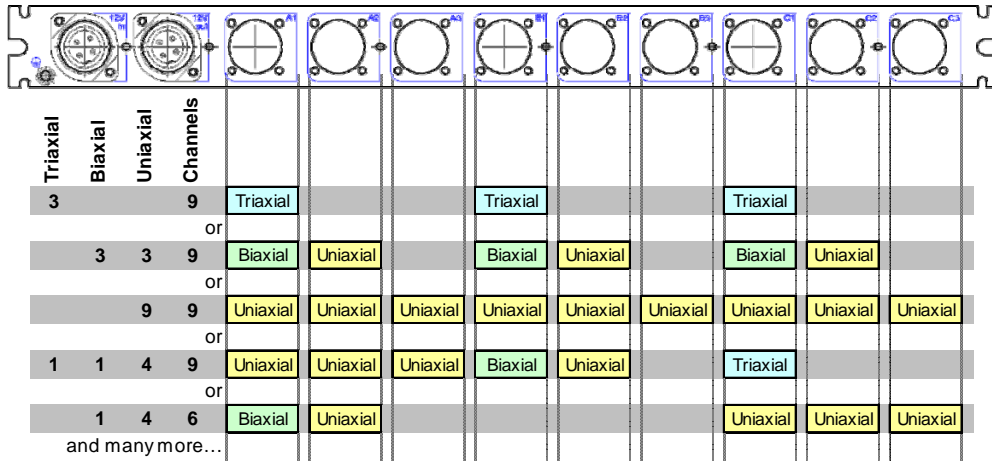

Figure 1. Some examples of possible sensor axes connectivity to a CR-5P system

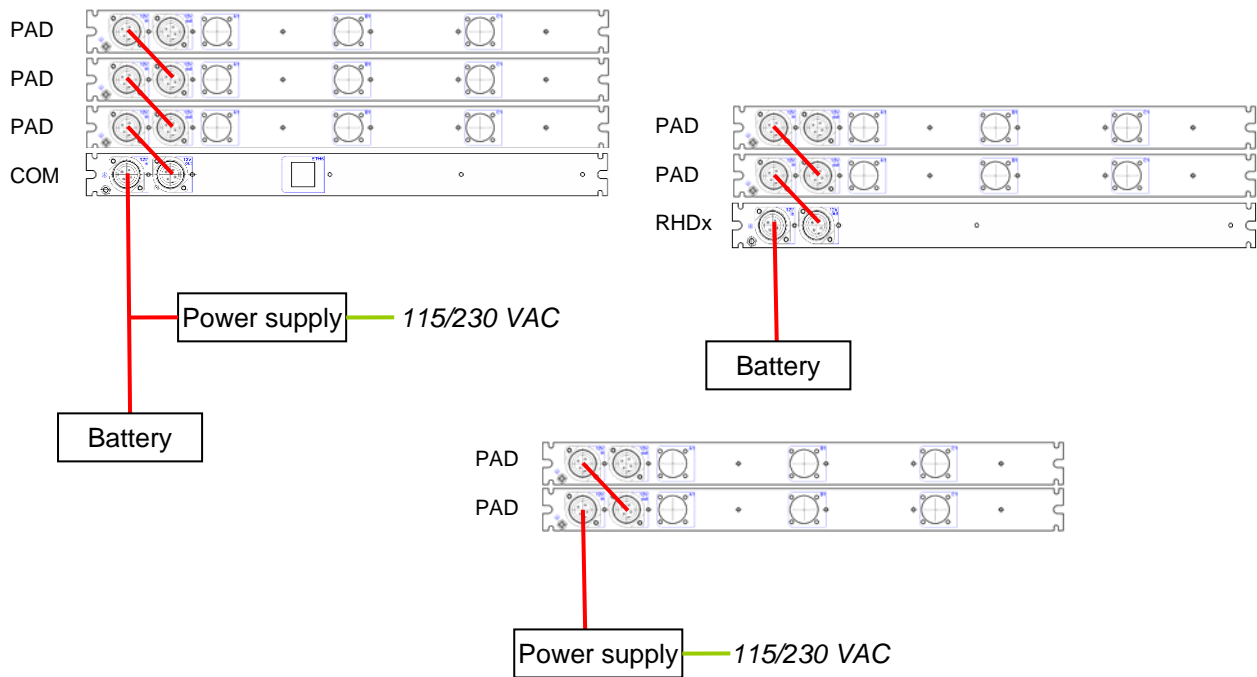

Figure 2. Example of powering a CR-5P system

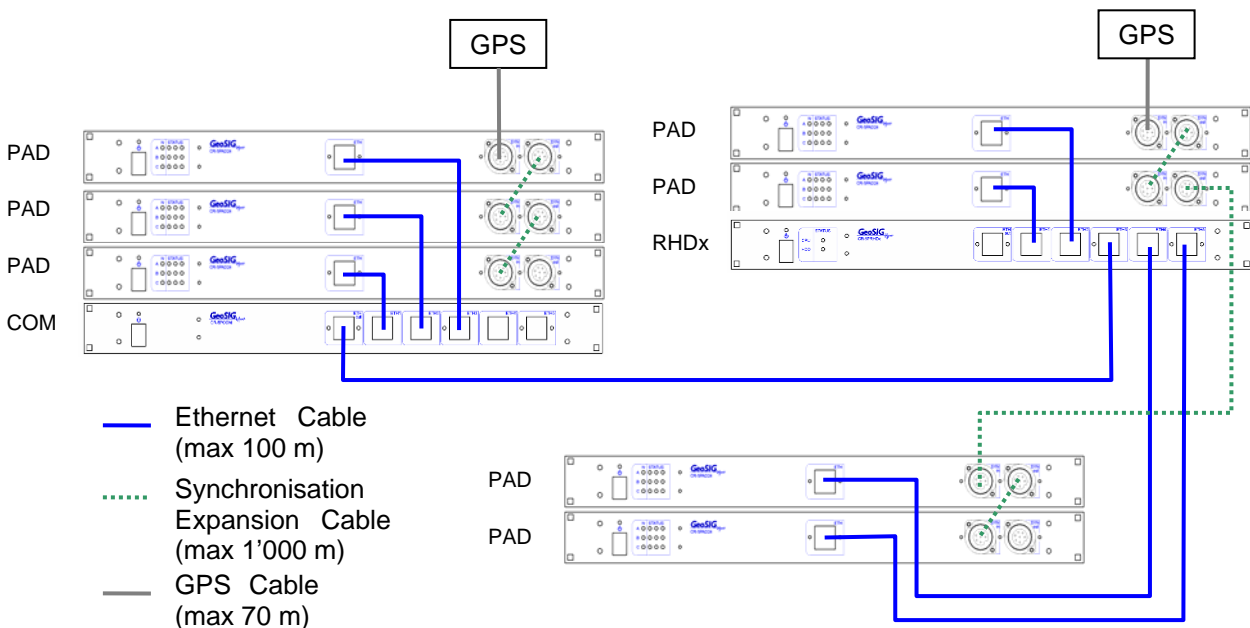

Figure 3. Example of networking a CR-5P system